



DV 400

Voltage (V): 400/230

Frequency (Hz): 50

STATIONARY WITHOUT CANOPY

KEY START



Technical Data Sheet

Technical information

PRP Power (kVA)	400
Standby Power (kVA)	450
PRP Power (kW)	320
Standby Power (kW)	360
Model	STATIONARY WITHOUT CANOPY

Weight and Dimensions (mm)

Length (L)	3430
Width (A)	1150
Height (H)	2207,5
Weight (kg)	3505
Fuel tank capacity (l)	540

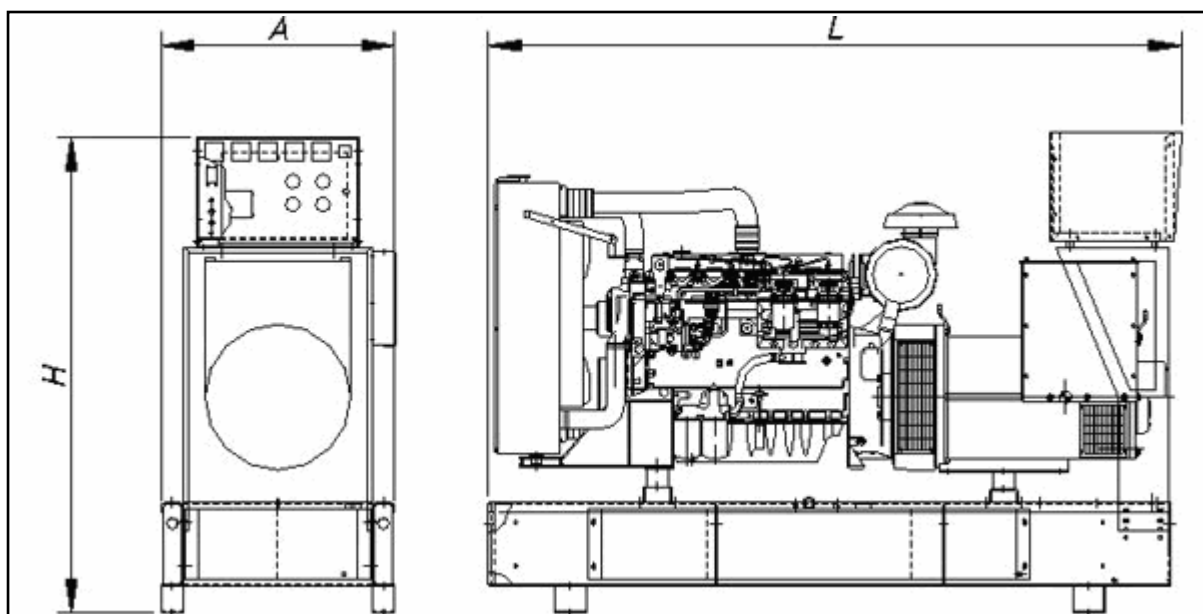

Consumption

	PRP Power		Standby Power	
	L/h	Range (hours)	L/h	Range (hours)
25%	20,9	25,8	22,8	23,7
50%	39,1	13,8	42,6	12,7
75%	57,8	9,3	63,3	8,5
100%	77,5	7	86,6	6,2

Engine

Brand	VOLVO
Model	TAD 1242 GE
Electronic Management	✓
No. of cylinders	6
Engine Capacity (c.c.)	12130
Bore (mm)	131
Stroke (mm)	150
Compression ratio	17,5:1
Water cooled	✓
Speed (r.p.m.)	1500

Cooling System

Flow of air from fan (m3/min)	351
-------------------------------	-----

Lubrication System

Oil sump capacity (l)	31
Maximum oil consumption (% fuel consumption)	0,18

Exhaust System

Input diameter (")	5
Output diameter (")	5
Body diameter (mm)	249
Exhaust length (mm)	840
T ^a gas emission (°C)	505
Gas flow (m3/min)	64

Alternator

Model	HCI 4_4 F1
Electronic Regulation	✓
AVR	AS440
Power (kVA)	400

Electric Panel

Measuring Instruments

Frequency meter	1
Hour meter	✓
Fuel gauge	✓

Control Instruments

Control Card	DEEP SEA 5310 RS485
Auto Start-up. mains failure	✓
Manual start-up	✓
Remote start-up	✓

Alarms

Start-up failure	✓
Battery charge failure	✓
Low oil pressure	✓
High engine water temperature	✓
Low Fuel Level	✓
Emergency Stop	✓
Overspeed	✓
Maintenance due	✓

Standby Gen-sets

Electric Panel

Auto/Manual Function	✓
Remote control software	✓
RS 485 communication port	✓
Protection Devices	
Emergency stop button	✓
Circuit breaker	4P 630A R

Head office address:

Pol. Indl Malpica-Alfinden. C/Encina 8
50171 La Puebla de Alfindén (Zaragoza) España
Tfno: +34 976 107 332 Fax: +34 976 107 366
info@gesan.com www.gesan.com

Grupos Electrógenos Gesan reserves the right to modify any characteristic without prior notice. Photos based on product standards, being possible to add optional elements.